

HF2000E-SJB Series (RoHS认证产品)

DC电源用 1000VDC

适用于大型太阳能发电系统发电面板方面



UL1283 (file No.E102708)
EN60939-2 (file No.R50221931)

用途

适用于大型太阳能发电系统的功率调节器发电面板方面(直流)

规格

Part No.	Rated Current	Weight	
HF2300E-SJB	300A	5.9kg	fig1
HF2600E-SJB	600A	5.9kg	
HF21000E-SJB	1000A	8.8kg	fig2
HF21200E-SJB	1200A	16kg	fig3
HF21600E-SJB	1600A	16kg	fig4
Rated Voltage	1000VDC max		
Ambient temp.	-25 up to 60 Deg.C		

fig.1 (300, 600A)

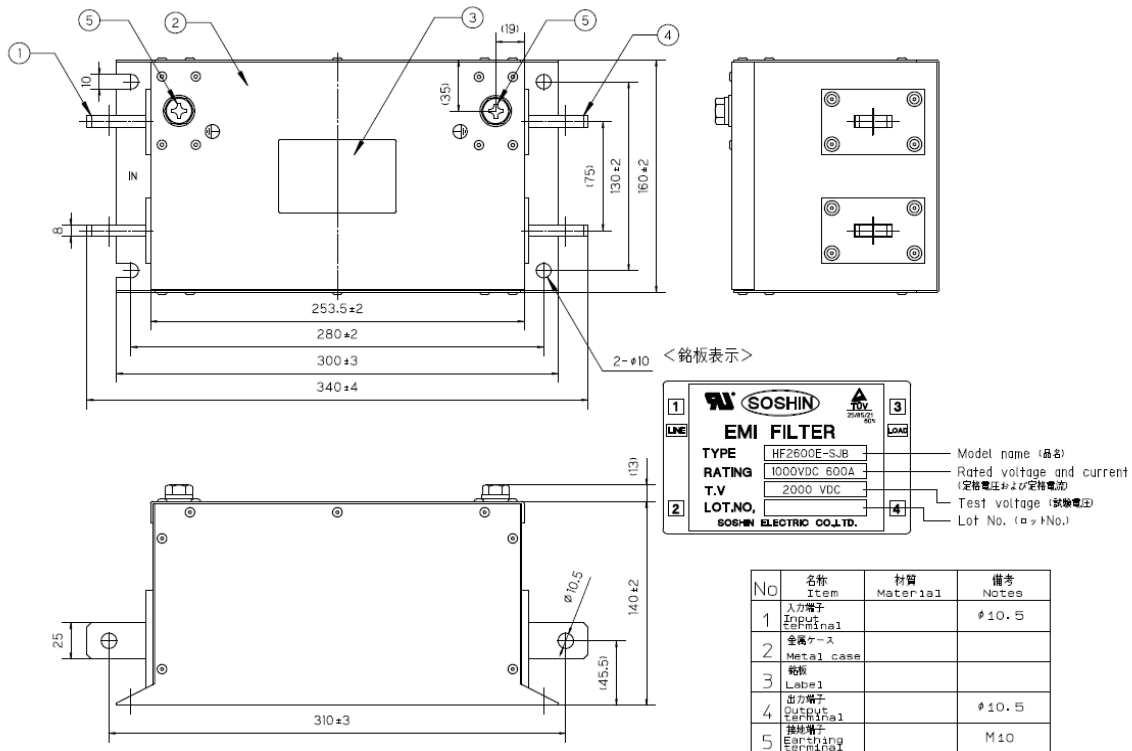
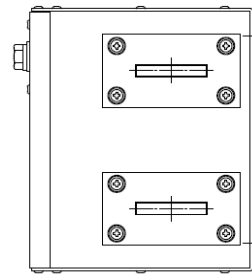
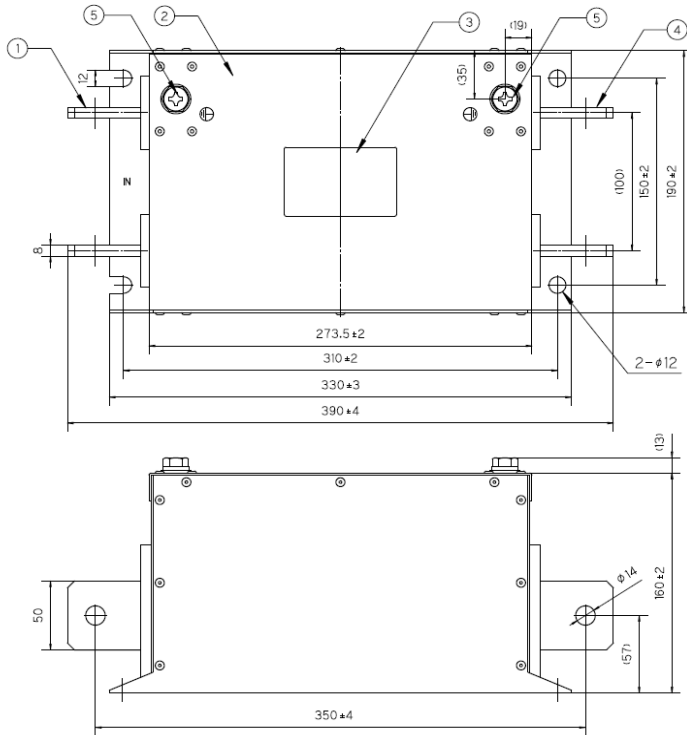
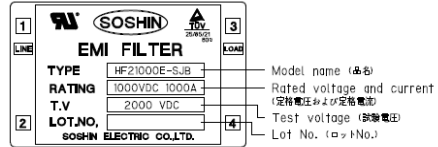

fig.2 (1000A)



<銘板表示>



No	名称 Item	材質 Material	備考 Notes
1	入力端子 Input terminal		φ14
2	金属ケース Metal case		
3	銘板 Label		
4	出力端子 Output terminal		φ14
5	接地端子 Earthing terminal		M10

fig.3 (1200A)

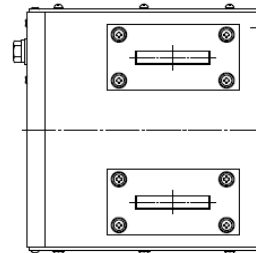
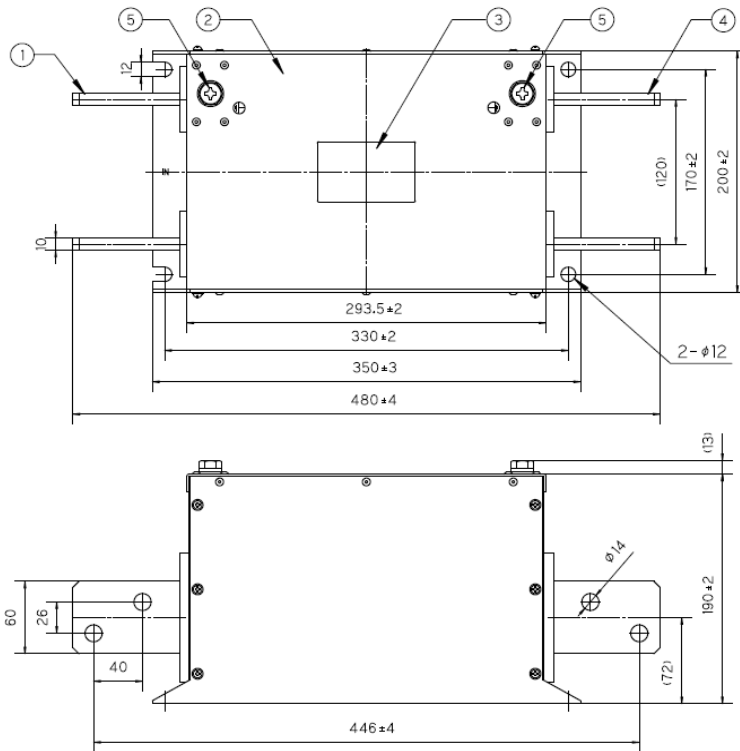

<銘板表示>

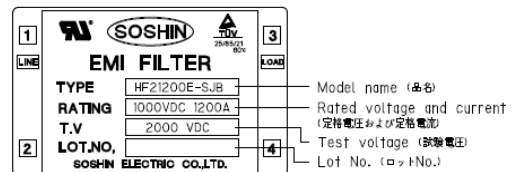

No	名称 Item	材質 Material	備考 Notes
1	入力端子 Input terminal		φ14
2	金属ケース Metal case		
3	銘板 Label		
4	出力端子 Output terminal		φ14
5	接地端子 Earthing terminal		M10

fig.4 (1600A)

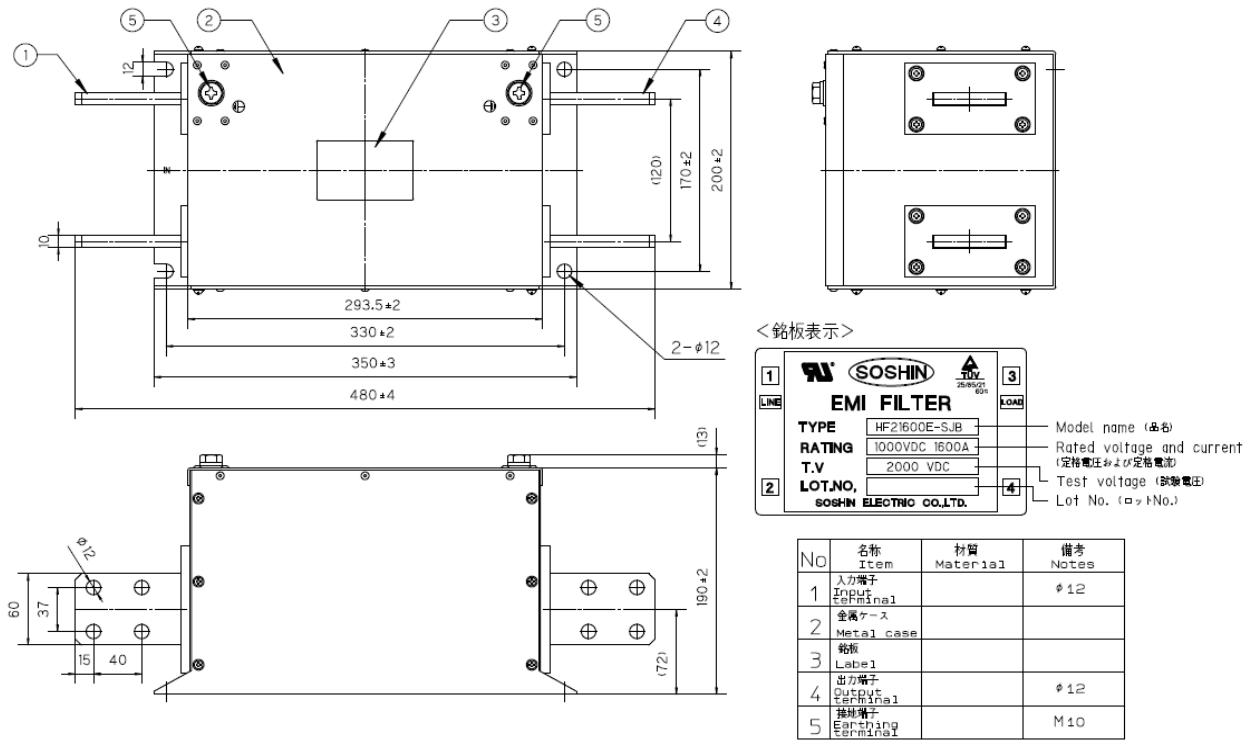

代表特性 (600A)

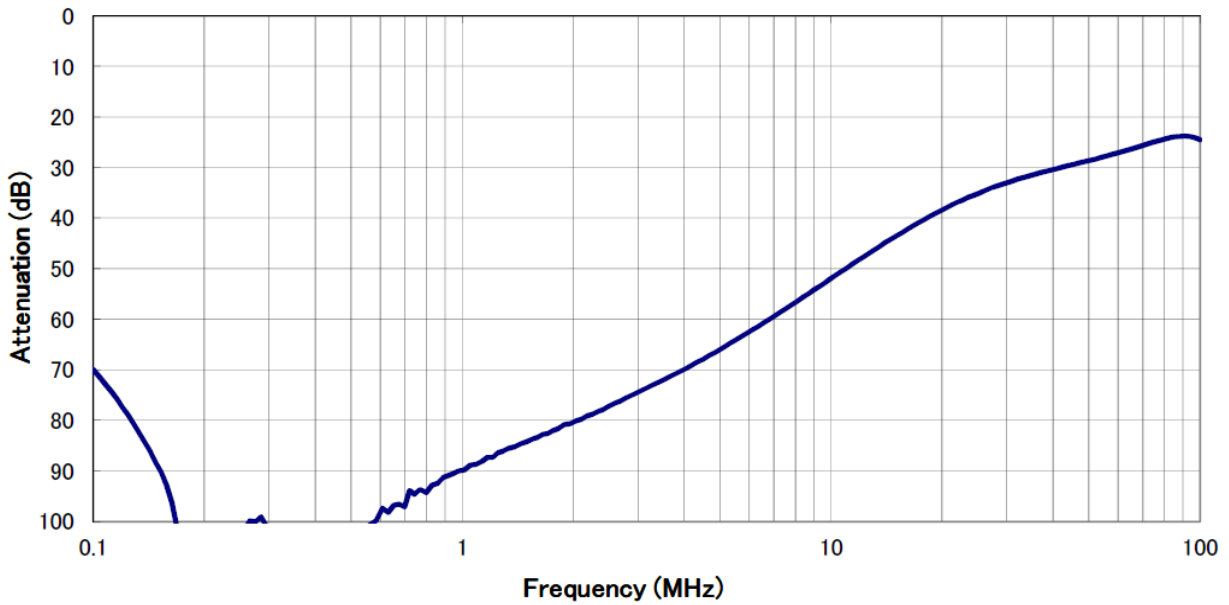

代表特性 (1600A)

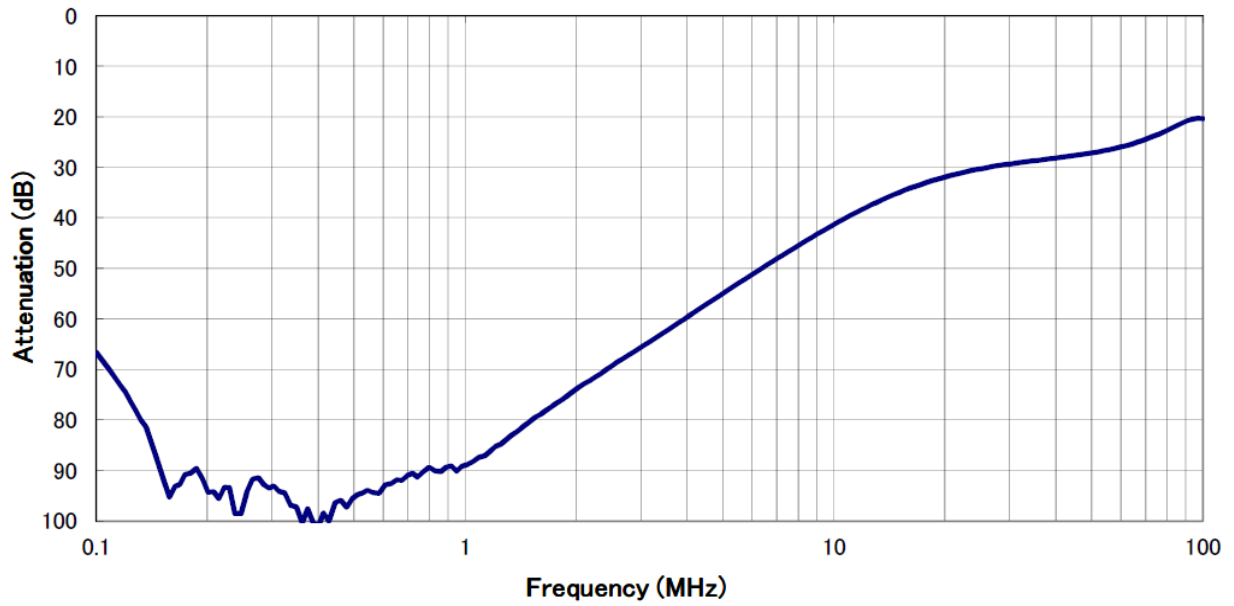

回路図

