

HF3000C-UQ Series (RoHS Compliant)

3-phase 3-line 480VAC

Large current & High attenuation



320A

[320A~600A]



UL1283 (file No.E102708)
EN60939-2 (file No.R50031225)

Applications

IGBT Inverter, AC Servo, NC Machinery

Specifications

Part No.	Rated Current	Weight	
HF3320C-UQ	320A	7.7kg	fig1
HF3400C-UQ	400A	7.7kg	
HF3600C-UQ	600A	7.7kg	
HF3900C-UQ	900A	15kg	fig2
HF31200C-UQ	1200A	25kg	fig3
HF31600C-UQ	1600A	33kg	fig4
Rated Voltage	480VAC max		
Leakage Current	375mA max/480VAC 60Hz By UL1283		
Ambient temp.	-10 up to 50 Deg.C		

fig.1 (320, 400, 600A)

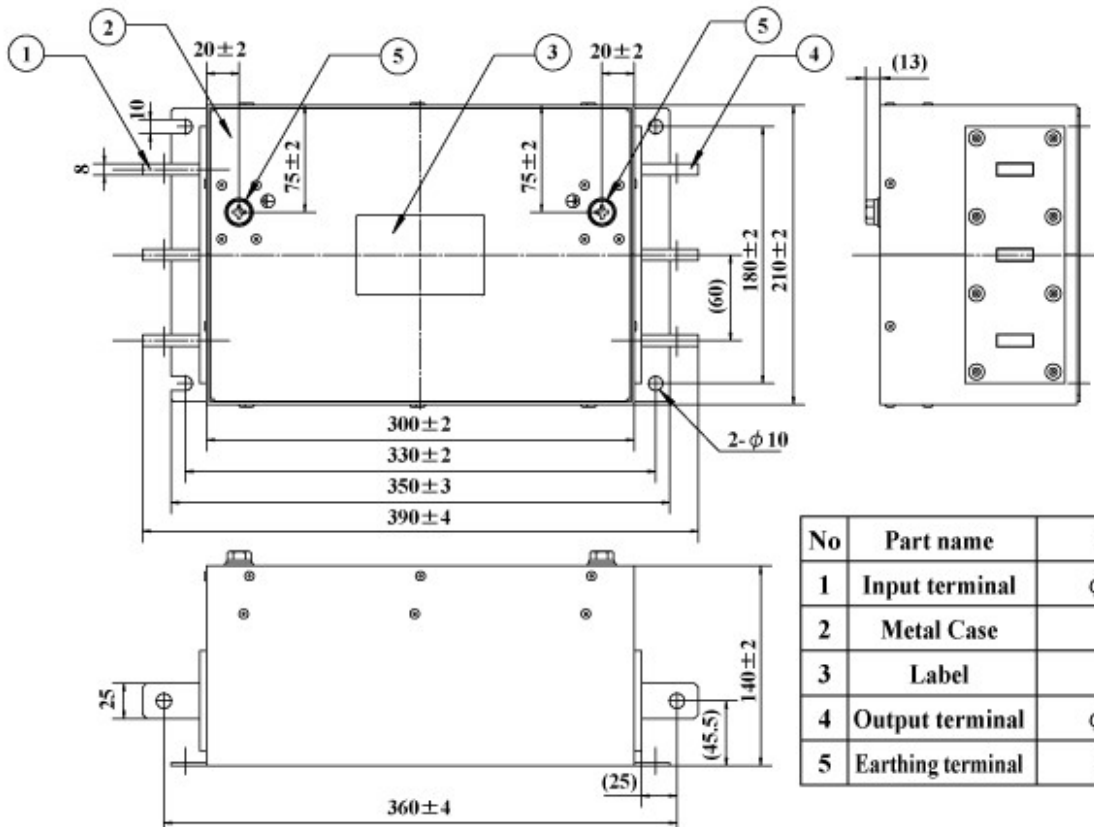

No	Part name	Note
1	Input terminal	φ 10.5
2	Metal Case	
3	Label	
4	Output terminal	φ 10.5
5	Earthing terminal	M10

fig.2 (900A)

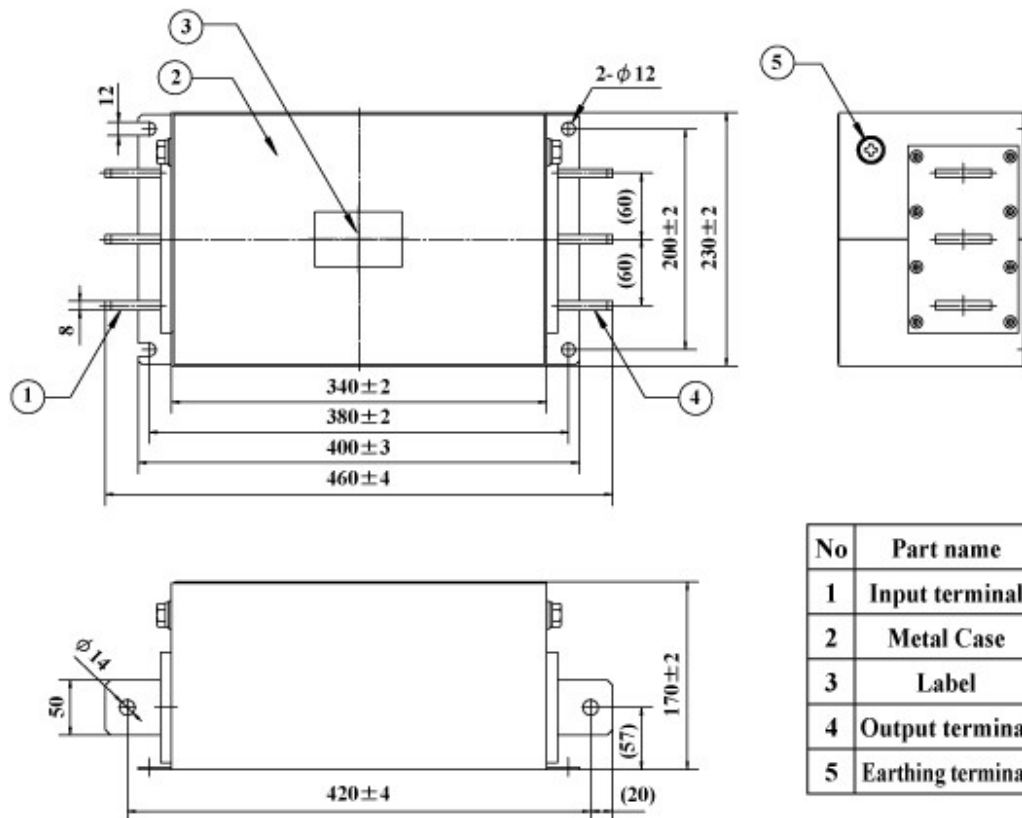

fig. 3 (1200A)

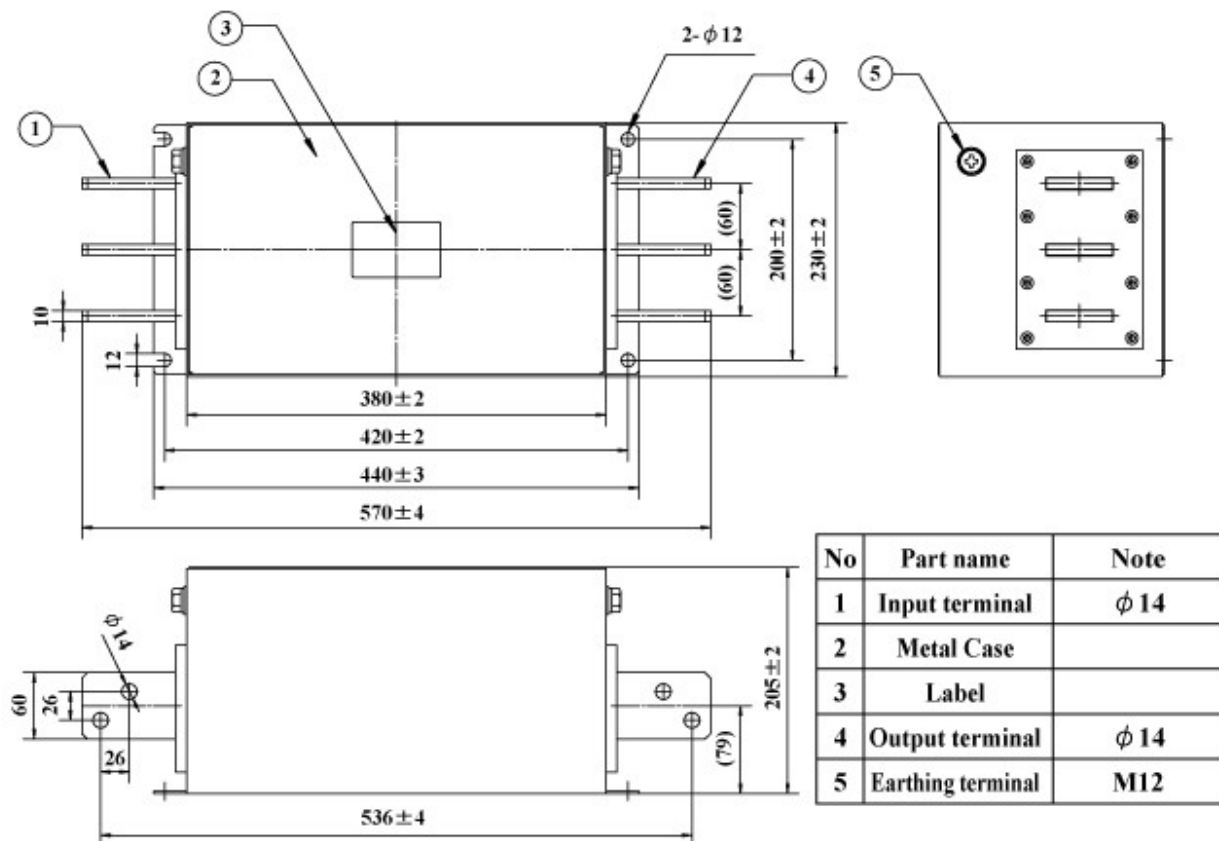
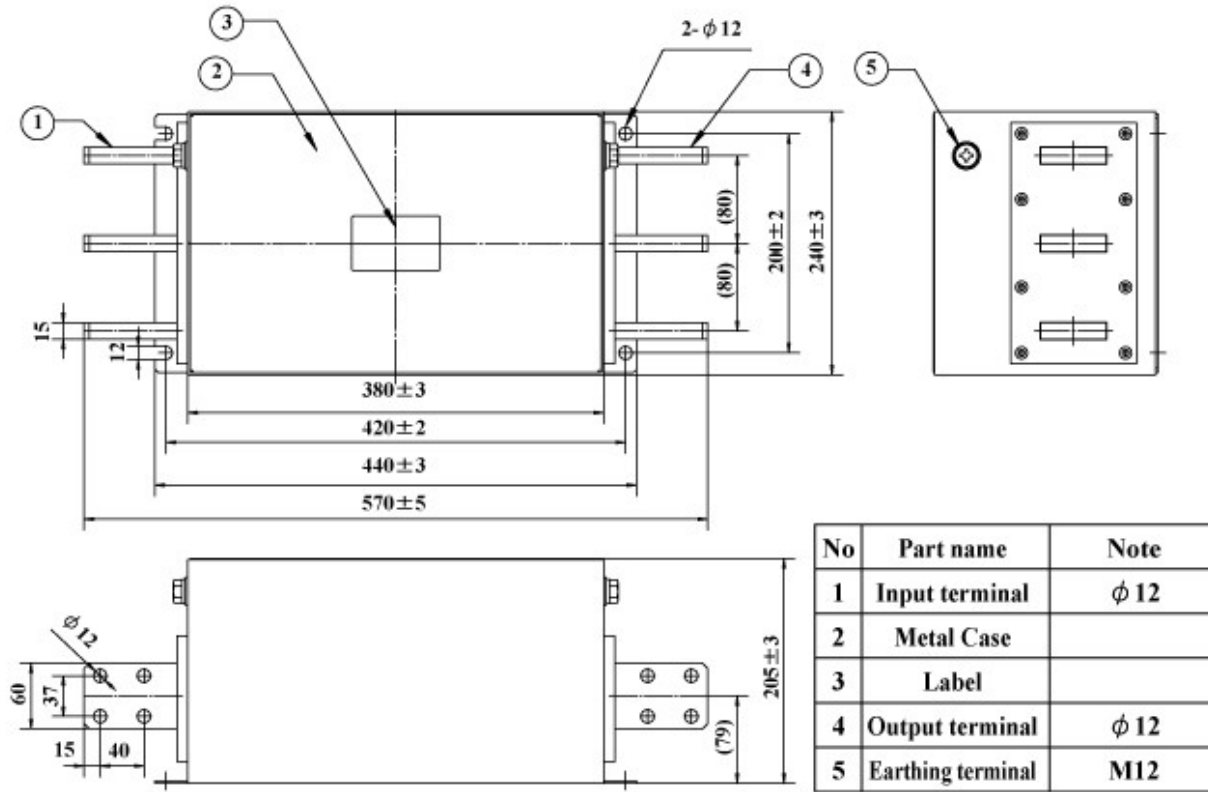
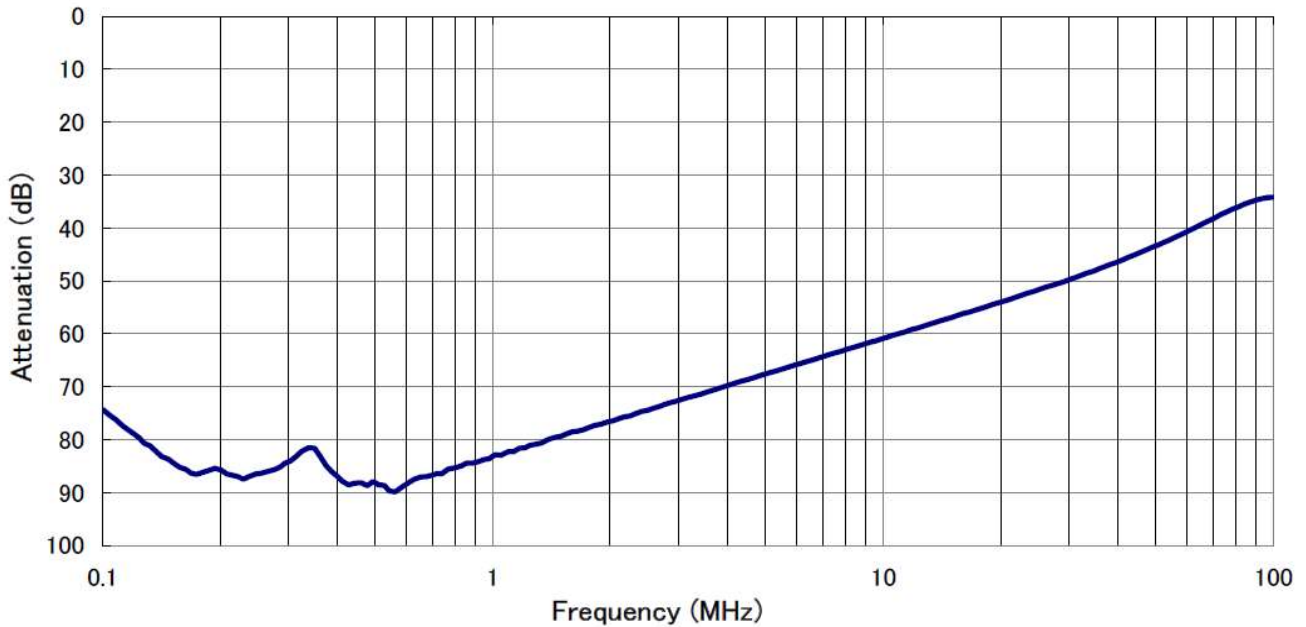

fig. 4 (1600A)



Attenuation Characteristics (320A)



Circuit Diagram

